

T 100 DES

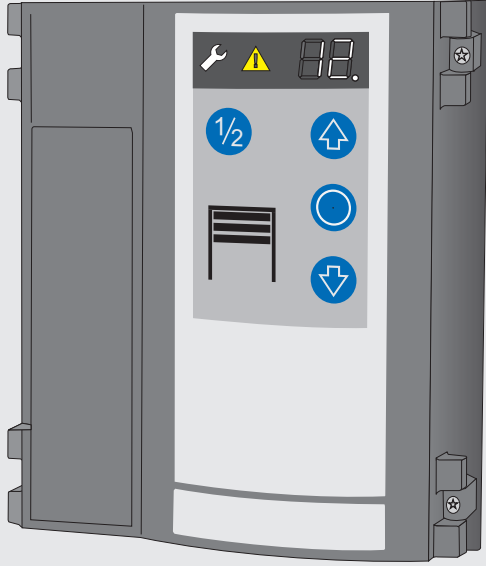

GB Mounting and operating instructions

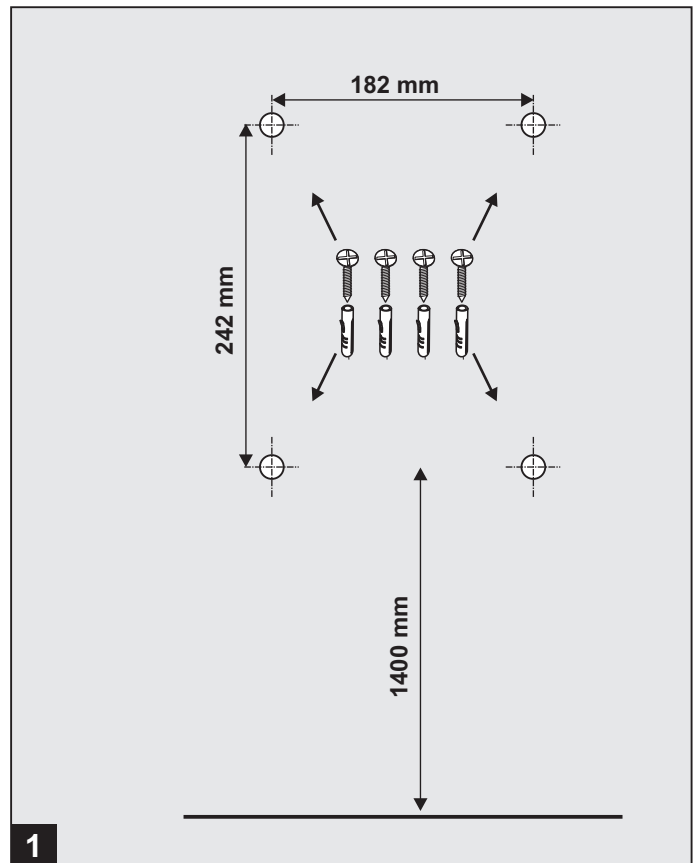

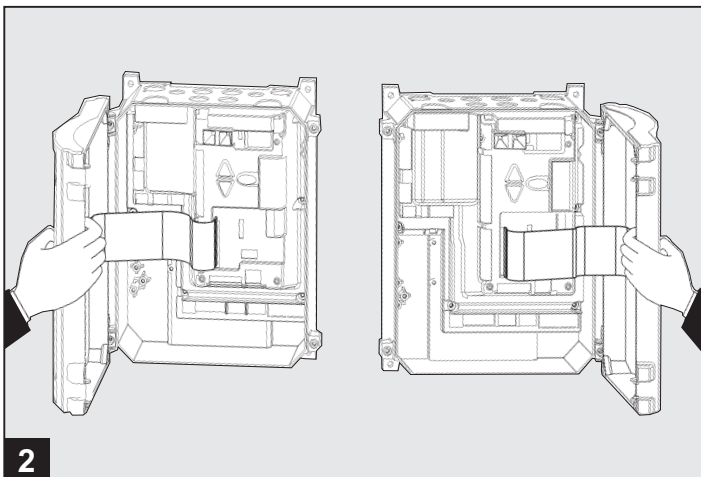
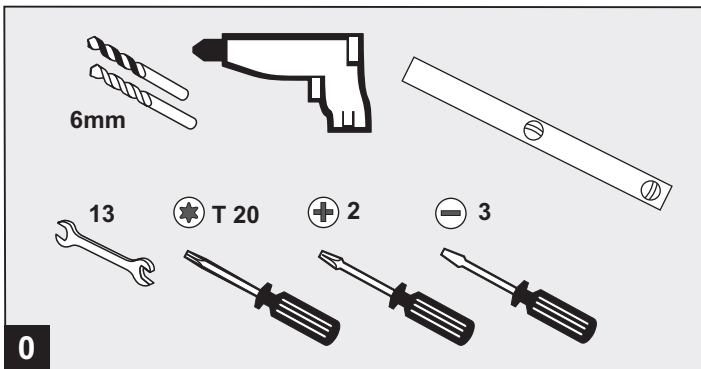
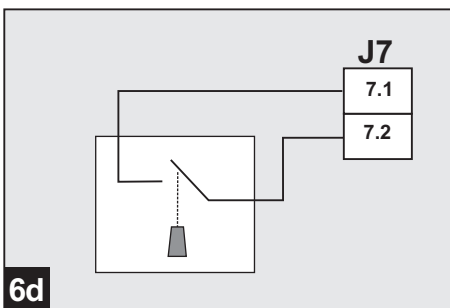
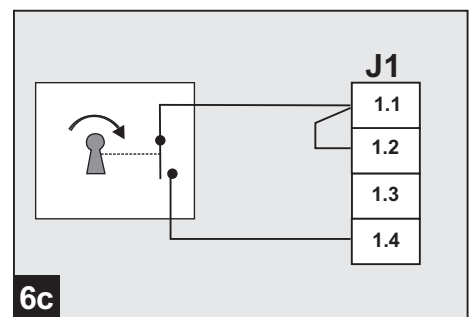
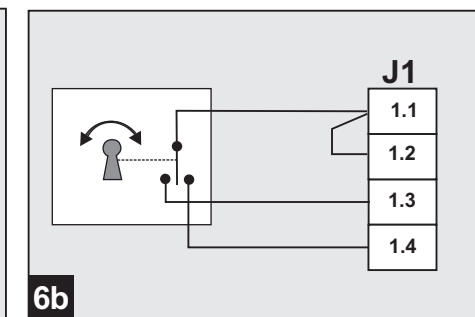
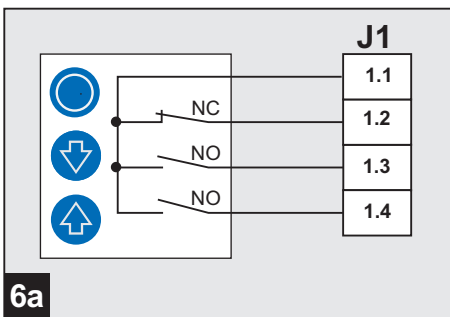
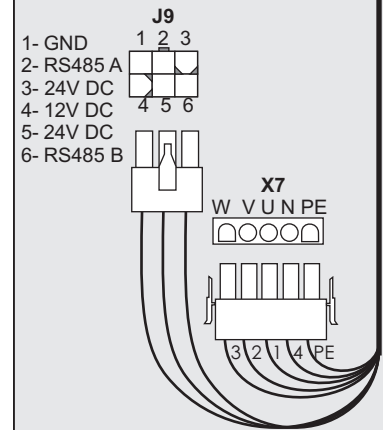
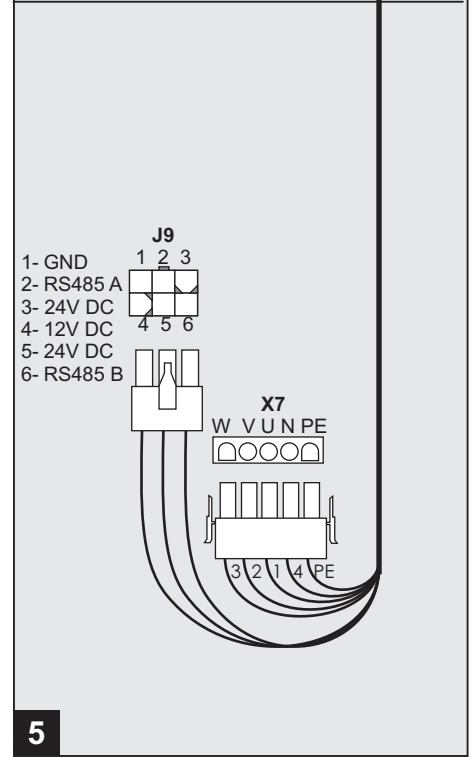
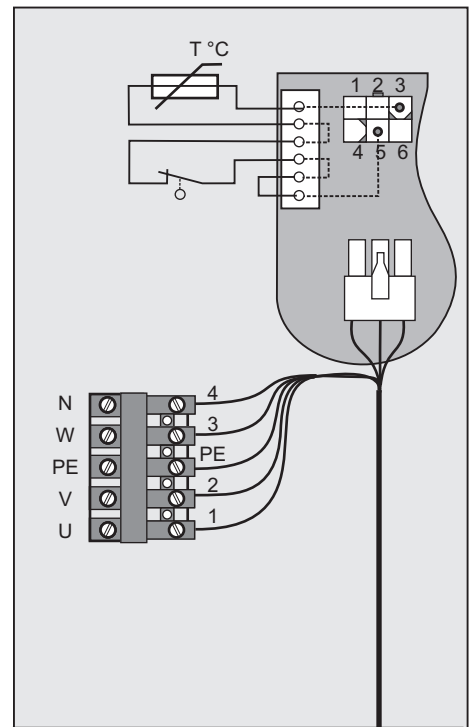
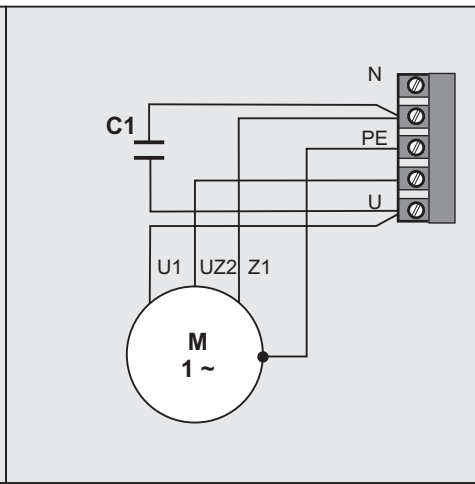
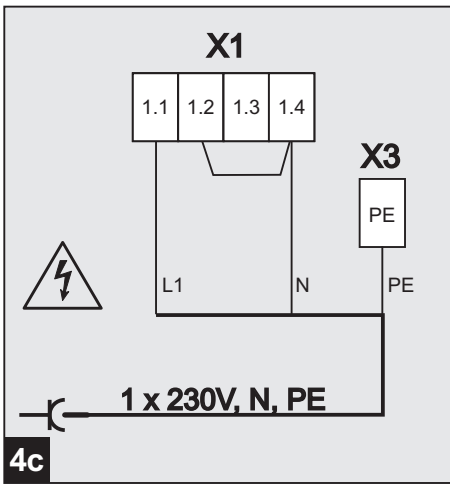
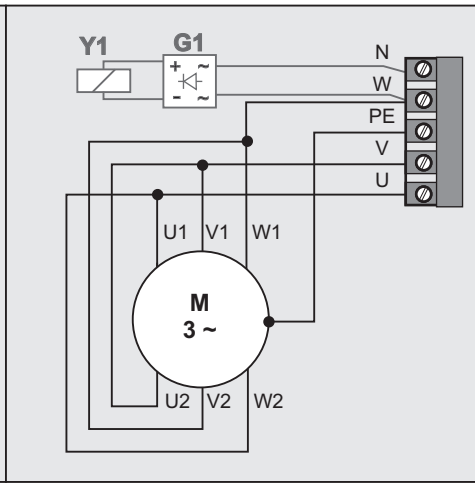
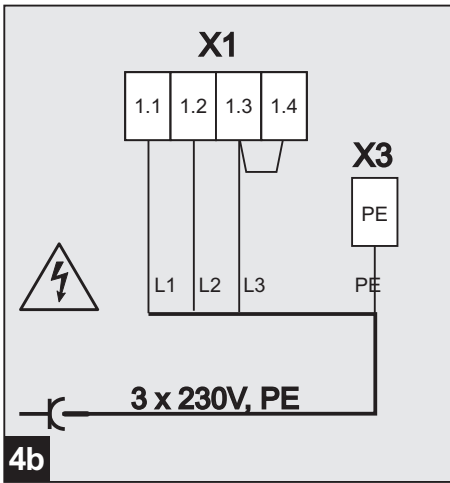
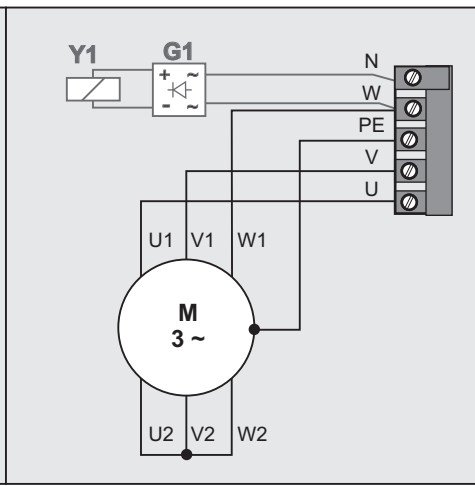
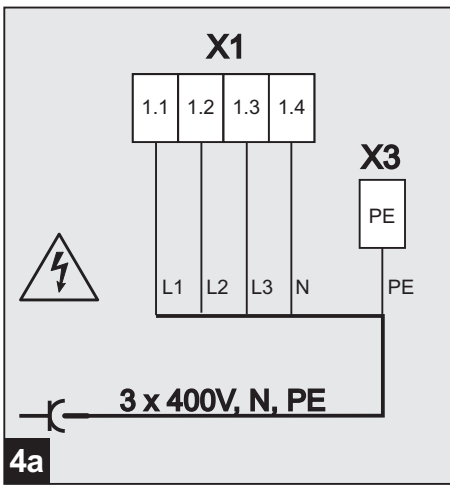

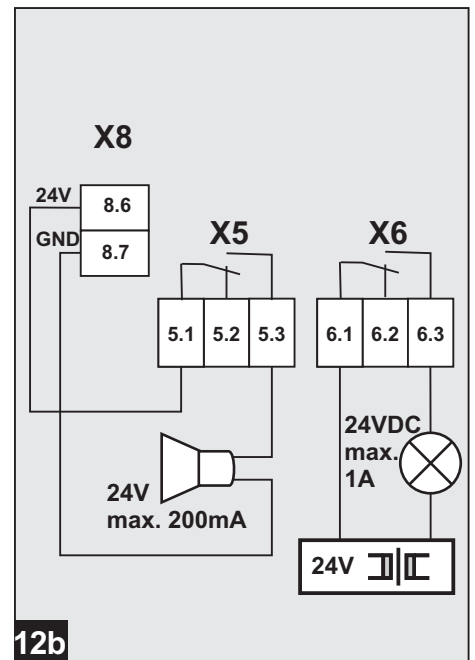
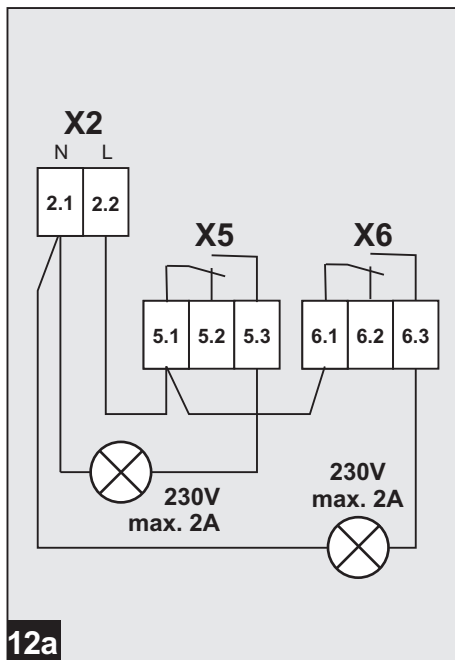
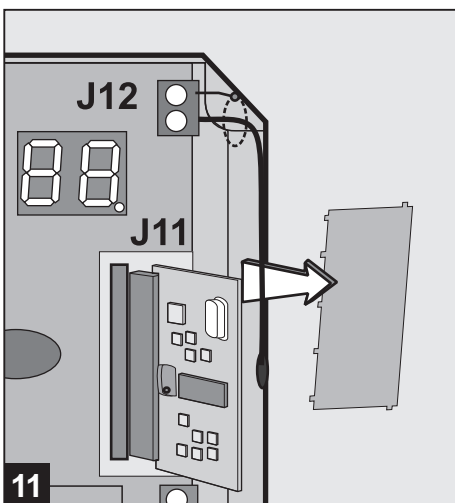
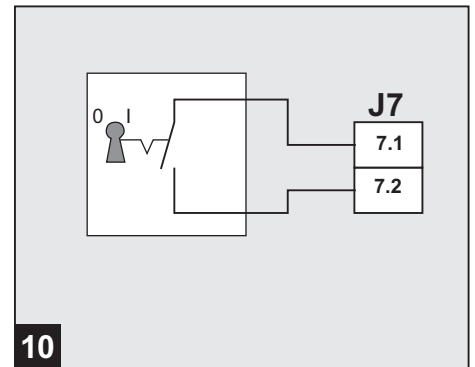
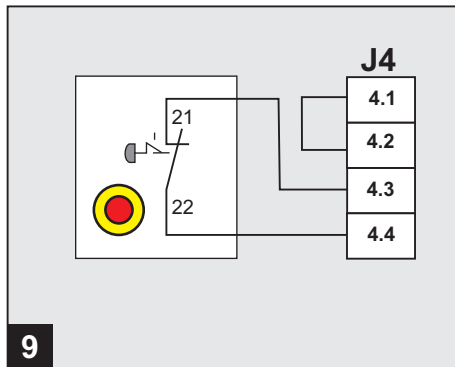
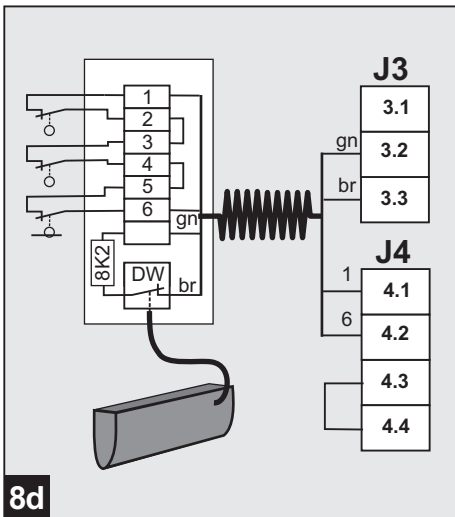
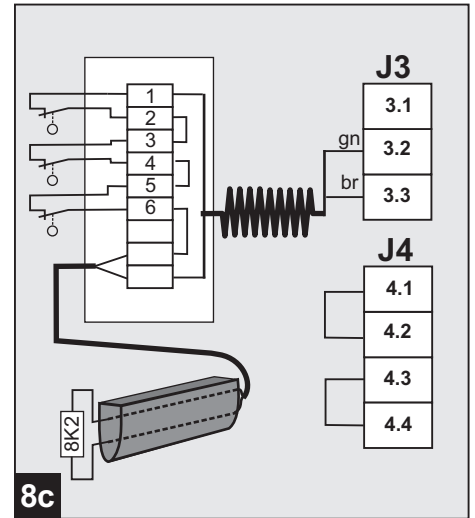
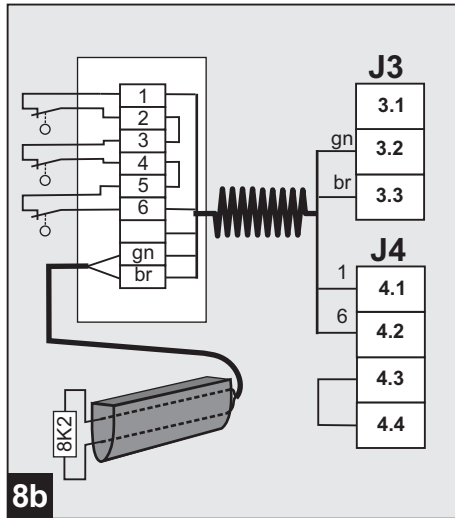
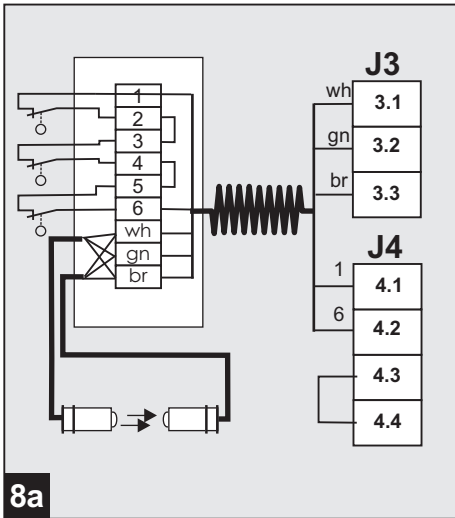
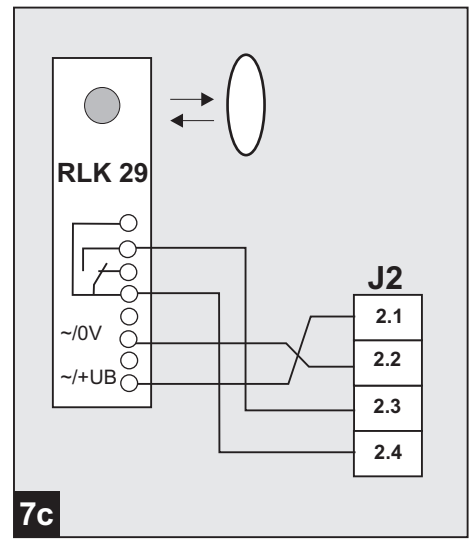
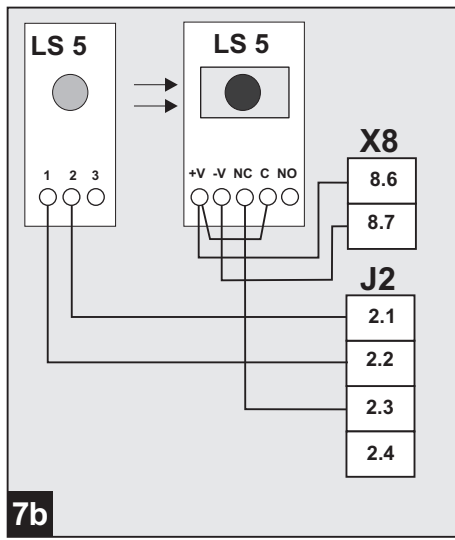
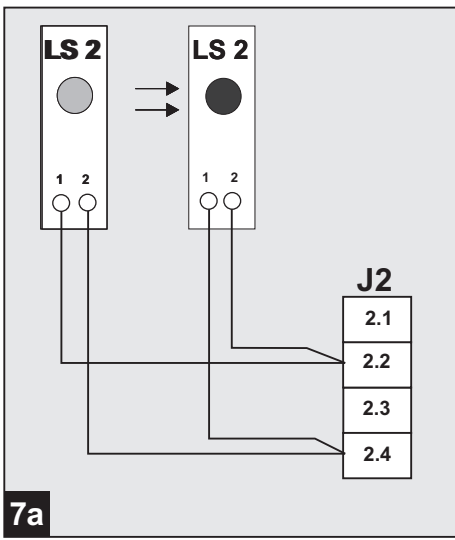

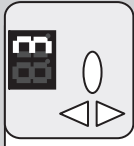
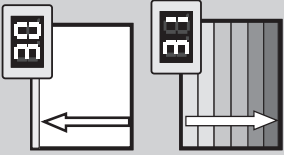

- D** Einstellungen obere [30] und untere [31] Torendlage
- GB** Setting the door's top [30] and bottom [31] end-of-travel position
- FR** Réglage de la position de fin de course supérieure [30] et inférieure [31] de la porte
- ES** Configurar la posición superior [30] e inferior [31] final de la puerta
- NL** Instellen van de bovenste [30] / onderste [31] eindpositie van de deur
- PT** Ajuste da posição final superior [30] / inferior [31]
- I** Impostazione posizione finale superiore [30] / inferiore [31] del portone
- DK** Indstilling øverste [30] / nederste [31] port-stoppunkt
- SE** Inställning av portens övre [30] / undre [31] slutposition
- N** Innstilling øvre [30] / nedre [31] portendstilling
- CZ** Nastavení horní [30] / spodní [31] koncové polohy vrat
- FIN** Oven ylä- [30] ja alaraja-asennon [31] säädöt
- PL** Nastawy górnego [30] i dolnego [31] położenia krańcowego bramy

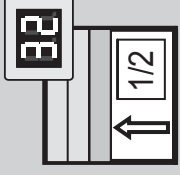
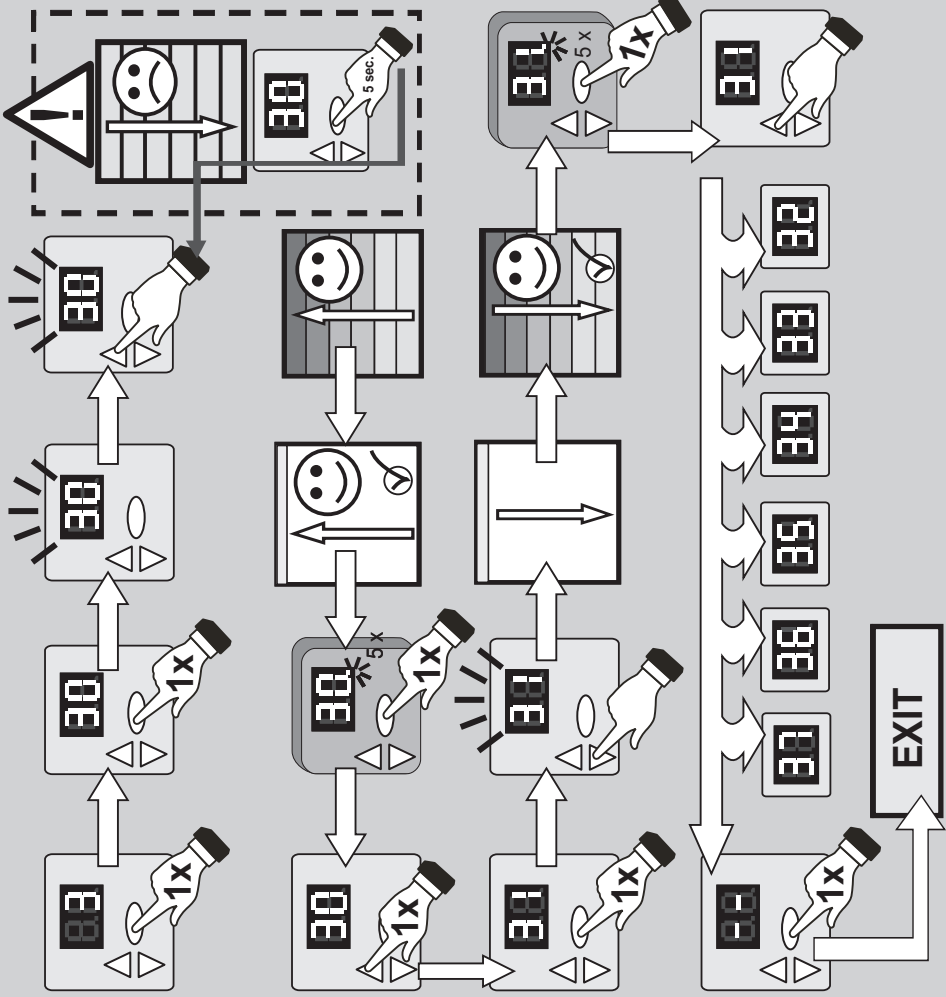

- D** Einstellen 1/2 Toröffnung [32]
- GB** Setting the door to the half-open position [32]
- FR** Réglage de la 1/2 ouverture de porte [32]
- ES** Configuración de 1/2 apertura de la puerta [32]
- NL** Instellen deur half open [32]
- PT** Ajuste da abertura parcial do portão (1/2) [32]
- I** Impostazione apertura portone a metà [32]
- DK** Indstilling 1/2 portåbning [32]
- SE** Inställning av en 1/2 portöppning [32]
- N** Innstilling 1/2 portåpning [32]
- CZ** Nastavení 1/2 otevření vrat [32]
- FIN** Oven saátö [32] puoleksi auki
- PL** Nastawianie 1/2 otwarcia bramy [32]

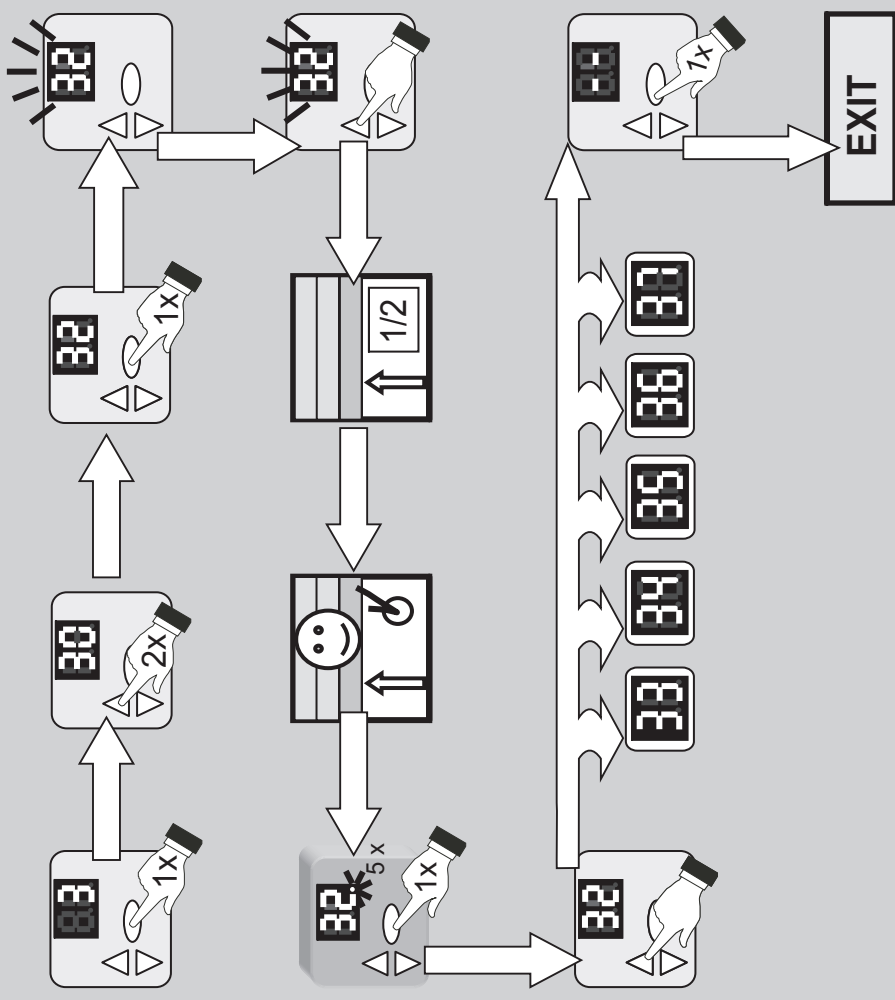

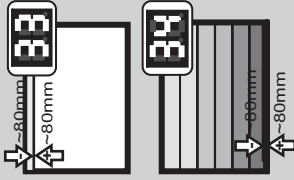

D Feininstellung Torendlage oben [33] und unten [34]
GB Fine adjustment of the top [33] and bottom [34] end-of-travel position
FR Réglage précis de la position de fin de course supérieure [33] et inférieure [34]
ES Configuración precisa de la posición final superior [33] e inferior [34]
NL Fijn instellen van de bovenste [33] / onderste [34] eindpositie van de deur
PT Ajuste preciso da posição final superior [33] / inferior [34]
I Microregolazione posizione finale superiore [33] / inferiore [34] del portone
DK Finindstilling øverste [33] / nederste [34] stoppunkt
SE Fininställning av den övre [33] / undre [34] slutpositionen
N Fininnstilling øvre [33] / nedre [34] endestilling
CZ Přesné nastavení horní [33] / spodní [34] koncové polohy
FIN Oven ylä- [33] ja alaraja-asennon [34] hienosäätö
PL Nastawa dokładna położenia krańcowego bramy u góry [33] i u dołu [34]

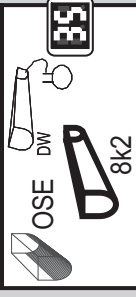
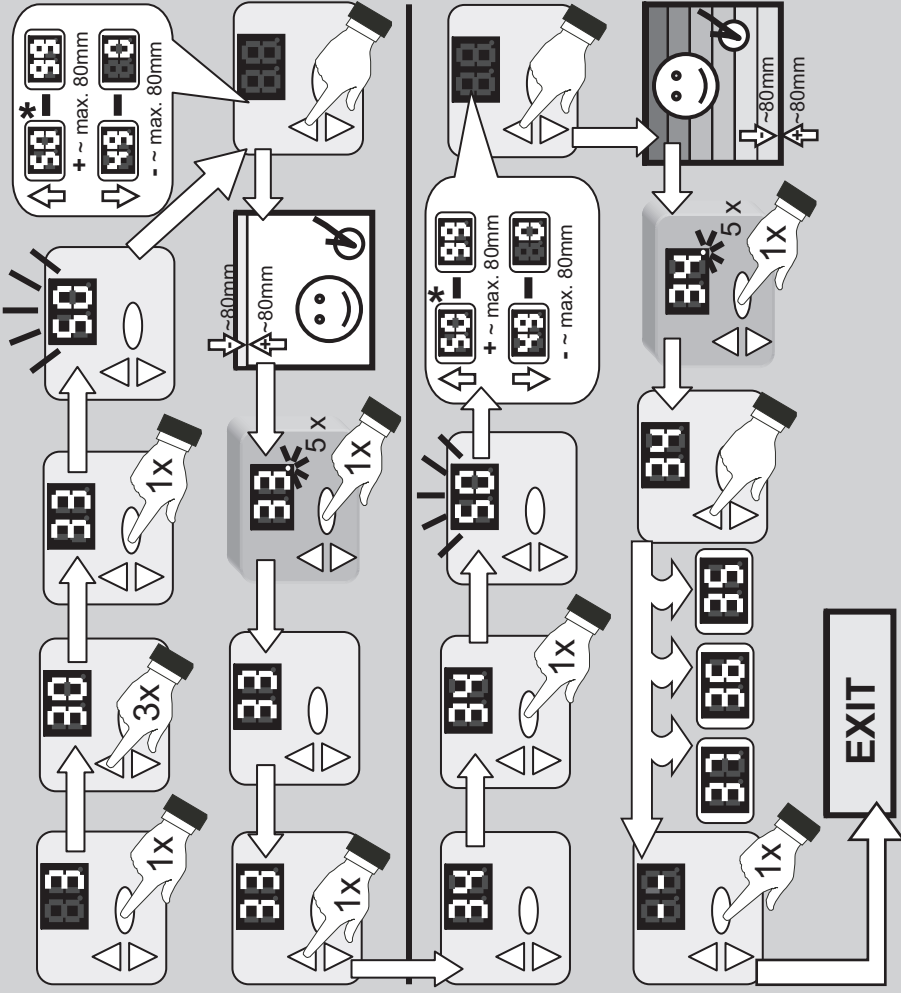
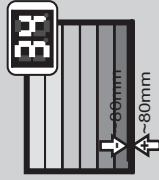

D Auswahl Schließkante J3 [35] / Auswahl Lichtschranke J4 [36]
GB Selecting the closing edge J3 [35] / Selecting the photoeye J4 [36]
FR Sélection du profil de sécurité optique J3 [35] et de la barrière photoélectrique J4 [36]
ES Selección de los cantos de cierre J3 [35] y de la barrera fotoeléctrica [36]
NL Keuze van de sluitkant J3 [35] / Keuze van de fotocel J4 [36]
PT Seleção do perfil de fecho [35]/ da barreira fotoelétrica [36]
I Selezione del bordo di chiusura [35] / della fotocellula [36]
DK Valg af lukkekant J3 [35] / Valg af fotocelle J4 [36]
SE Val av tillutningskant [35] / Val av fotocell [36]
N Valg av lukkekant [35] / Valg av fotocelle [36]
CZ Výběr uzavírací hrany [35] / Výběr optické závory [36]
FIN Sulku reunan J3 [35] valinta/valokennon J4 [35] valinta
PL Wybór krawędzi zamykającej J3 [35]/Wybór zapory świetlonej J4 [36]

D Auswahl Schließkante J3 [35] / Auswahl Lichtschranke J4 [36]
GB Selecting the closing edge J3 [35] / Selecting the photoeye J4 [36]
FR Sélection du profil de sécurité optique J3 [35] et de la barrière photoélectrique J4 [36]
ES Selección de los cantos de cierre J3 [35] y de la barrera fotoeléctrica [36]
NL Keuze van de sluitkant J3 [35] / Keuze van de fotocel J4 [36]
PT Seleção do perfil de fecho [35]/ da barreira fotoelétrica [36]
I Selezione del bordo di chiusura [35] / della fotocellula [36]
DK Valg af lukkekant J3 [35] / Valg af fotocelle J4 [36]
SE Val av tillutningskant [35] / Val av fotocell [36]
N Valg av lukkekant [35] / Valg av fotocelle [36]
CZ Výběr uzavírací hrany [35] / Výběr optické závory [36]
FIN Sulku reunan J3 [35] valinta/valokennon J4 [35] valinta
PL Wybór krawędzi zamykającej J3 [35]/Wybór zapory świetlonej J4 [36]

D Auswahl Schließkante J3 [35] / Auswahl Lichtschranke J4 [36]
GB Selecting the closing edge J3 [35] / Selecting the photoeye J4 [36]
FR Sélection du profil de sécurité optique J3 [35] et de la barrière photoélectrique J4 [36]
ES Selección de los cantos de cierre J3 [35] y de la barrera fotoeléctrica [36]
NL Keuze van de sluitkant J3 [35] / Keuze van de fotocel J4 [36]
PT Seleção do perfil de fecho [35]/ da barreira fotoelétrica [36]
I Selezione del bordo di chiusura [35] / della fotocellula [36]
DK Valg af lukkekant J3 [35] / Valg af fotocelle J4 [36]
SE Val av tillutningskant [35] / Val av fotocell [36]
N Valg av lukkekant [35] / Valg av fotocelle [36]
CZ Výběr uzavírací hrany [35] / Výběr optické závory [36]
FIN Sulku reunan J3 [35] valinta/valokennon J4 [35] valinta
PL Wybór krawędzi zamykającej J3 [35]/Wybór zapory świetlonej J4 [36]

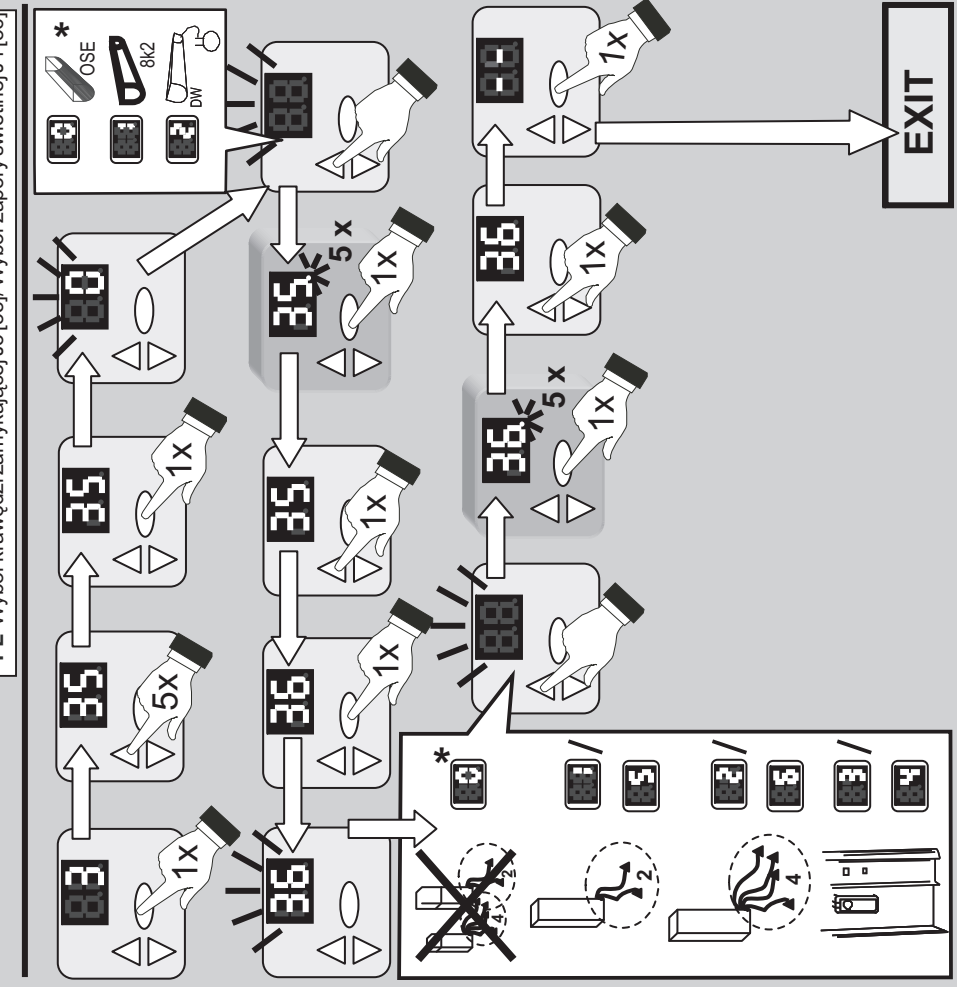

T100 DES

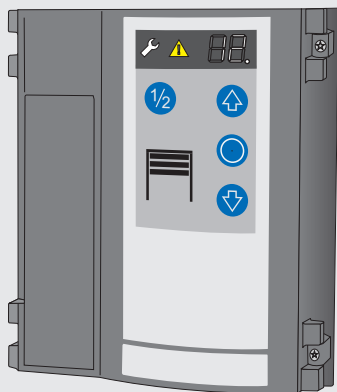

Table of contents

- **General Information**
 - Safety
 - Explanation of the symbols
 - Working safety
 - Hazards that may emanate from the product
 - Safety regulations
 - Spare parts
 - Changes and modifications to the product
 - Data plate
 - Packaging
 - Technical data
- **Installation**
- **Programming overview**
- **Operating instructions / Description of functions**
- **Maintenance / Checks**
- **Error Diagnosis**
- **Terms of Guarantee**
- **Inspection log book**
 - Inspection and Test Log Book for the Door System
 - Check List of the Door System
 - Proof of Inspection and Maintenance of the Door System
 - Declaration of Conformity and Installation

• General Information

• Safety

Before commencing any work on the product, carefully read through the operating instructions from start to finish, in particular the section entitled "Safety" and the related safety advice. It is important for you to have understood what you have read. This product could prove hazardous if not used properly as directed or in accordance with the regulations. Any damage occurring as a result of non-compliance with these instructions shall render the manufacturer's liability null and void.

• Explanation of the symbols



WARNING: imminent danger

This symbol indicates that instructions are being given which, if not observed, could lead to malfunctions and/or failure of the operator.



WARNING! Danger by electric current
The works may only be executed by an electrician.



This symbol indicates that instructions are being given which, if not observed, could lead to serious injury.



Reference to text and figure

• Working safety

By complying with the safety advice and information provided in these Operating Instructions, injury to persons and damage to property whilst working on and with the product can be avoided.

Failure to observe the safety advice and information provided in these Operating Instructions as well as the accident prevention and general safety requirements relevant to the field of application shall exempt the manufacturer or its authorized representatives from all liability and shall render any damage claims null and void.

• Hazards that may emanate from the product

The product has been subjected to a risk assessment. The design and execution of the product based on this corresponds to state-of-the-art technology.

When used properly as intended, the product is safe and reliable to operate.

Nevertheless, a residual risk will always remain!

The product runs on a high electrical voltage. Before commencing any work on electrical systems, please observe the following:

1. Disconnect from the power supply
2. Safeguard to prevent a power restart
3. Check that the electricity supply is cut off.

• Safety regulations

When performing installation work, initial operation, maintenance jobs or testing the control unit, take care to observe the local safety regulations!

The following standards and regulations must be observed:

- European standards
- DIN EN 12445
Safety in Use of Power-operated Doors and Gates - Test Methods
 - DIN EN 12453
Safety in Use of Power-operated Doors and Gates - Requirements
 - DIN EN 12978
Protective Devices for Power-operated Doors and Gates - Requirements and Test Methods

In addition to the above, the normative references of the standards listed must be observed.

VDE regulations

- DIN EN 418
Safety of Machinery
Emergency-STOP device, functional aspects
Design principles
- DIN EN 60204-1 / VDE 0113-1
Electrical installations with electrical equipment
- DIN EN 60335-1 / VDE 0700-1
Safety of household and similar electrical appliances

• Spare parts

Only use genuine spare parts of the manufacturer.



Wrong or faulty spare parts can cause damage, malfunctions or even a total failure of the product.

• Changes and modifications to the product

In order to prevent hazards and ensure optimum performance, no changes, modifications or conversions may be made to the product that have not been expressly approved by the manufacturer.

• Data plate

The data plate is located under the control panel cover. Observe the specified power rating.

• Packaging

Always dispose of the packaging in an environmentally-friendly manner and in accordance with the local regulations on disposal.

Technical Data

Dimensions of housing

Height x width x depth

250mm x 215mm x 120mm

Mounting vertical

Number of cable lead-throughs

6 x M20,

2 x M16,

2 x M20 V-cutout

Supply voltage

3 x 400 V AC

3 x 230 V AC

Control voltage

24 V DC

Max. motor output

max. 3.0 kW

Protection classification

IP 54, optional IP 65

Operating temperature

- 20°C to + 55°C

Manufacturer:

Novoferm tormatic GmbH

Oberste-Wilms-Str. 15a

D-44309 Dortmund

Installation

0 Required tools

1 Installing the control unit

2 Opening the control unit cover

3 Connections

Designation:

J1	START / impulse input (OPEN / STOP / CLOSE)
J2	Safety photocell, two or four-wire
J3	Closing edge OSE / 8K2 / DW
J4	Emergency-STOP, slack cable, latching
J7	Key switch, pull button
J9	Digital limit switch - motor cable
J10	Connection of add-on controls
J11	Connection of radio receiver
J12	Aerial
J13	Membrane keypad
X1	Mains connection
X2	Mains output L, N (500 W / 230 V)
X3	Protective conductor contact
X5	Floating relay contact 1, door status relay
X5	Floating relay contact 2, door status relay
X7	Door operator
X8	24V DC, 200mA

4 Mains connection

The control unit comes ready-wired with a 16A CEE phase-changer plug and approx. 1 m of cable (see 4a).

! The unit must be connected to the mains in accordance with the existing power supply voltage.

5 Motor connecting lead

The connecting lead for the motor and digital limit switch (DES) is pre-assembled and ready to use - attach accordingly.

6 Impulse generator connection

If the gate is to be opened and closed by way of a key (Open-Stop-Closed), select the following:

- 6c Set value 1 in menu 51 or
- 6d Menu 50, factory setting

7 Photocell connection

The photocell must be correspondingly set/adjusted in menu 36.

7a Two-wire photocell LS2



During this process the closing procedure must not be interfered with, otherwise the wrong position could be recorded.

7b Four-wire photocell LS5 with self-testing

7c Reflection photocell RLK29

If in the menu the frame-fitted photocell has been selected, the next time the door closes the control unit automatically initiates a learning run to detect the position.

8 Safety edge connection

When using impulse control for door closing, connection of a safety edge is required. Select the corresponding setting in menu 35.

8a Optical closing edge OSE

8b Electrical safety edge 8K2 with a termination resistor of 8.2 kOhm

8c Electrical safety edge 8K2 in series connection with slack rope and wicket door switch

8d Pressure wave edge and switch with a loop resistance of 8.2 kOhm

9 Emergency-STOP connection

10 Key switch / pull button connection

When using a key switch / pull button, the desired function in menu 50 should be selected.

11 Radio remote control

Plug in receiver module (option) at J11 and initiate the hand transmitter learning procedure in menu 60, 61 or 62.

12 Relay output

2 change-over contacts:
max. 250VAC / 2A or 24VDC / 1A.
24V-output X8: max. 200mA
Selecting the relay function in menu 45 and 46.
If the AR mode has been selected in menu 40 (menu 3 or 4), the function early warning light will be assigned to X6. The settings in menu 46 will be ineffective.

Programming the control unit

The programming is menu-driven. Carry out adjustment of the door in accordance with the scheme. The following page shows the full extent of the menu.

Setting the door end-of-travel positions (menus 30 and 31)

! The door must be spring balanced.

Correcting the slowing-down path (menu 42)

Compensates changes in the closed position resulting from temperature fluctuations, gearbox run-in etc.

Level adjustment (menu 43)

Compensates changes in the closed position resulting from cable elongation or a rise in the floor level. Set the precise closed position beforehand, then set in menu 43.

Spring breakage detection (menu 47)

If the set value is exceeded, error E32 is displayed.

! After the springs have been renewed, the door end-of-travel positions need to be reset.

- Motor 9.24/5.24: input value = U x weight / 20 kg
- Motor 9.20: input value = U x weight / 16 kg
- Motor 9.15: input value = U x weight / 15 kg

Example:

Motor 9.24, U = 8 revolutions to open the door
Weight of the door leaf = 150 kg, each of the 2 springs bears 75 kg. Cut-off recommended at 60 kg.

Input value = $8 \times 60 \text{ kg} / 20 \text{ kg} = 24$



The quick release requires re-setting, otherwise spring fracture safeguards must be connected.

Check of the spring balancing device

Press the button  of menu 47 for 5 sec rather than only briefly, after the door has been completely opened and closed once.

The value indicates how the door is balanced:

- Motor 9.24/5.24: $F \text{ (kg)} = \text{display value} \times 20 \text{ kg} / U$
- Motor 9.20: $F \text{ (kg)} = \text{display value} \times 16 \text{ kg} / U$
- Motor 9.15: $F \text{ (kg)} = \text{display value} \times 15 \text{ kg} / U$

U = number of revolutions for one door opening
If the display value ranges between -2 and -9, the springs are over-tensioned.

The results are only approximate values; a force measuring run is required to determine the value more precisely.

Opening force limit (menu 48)

The door's opening movements are compared with one another. If the set value is exceeded, the door stops and F33 is displayed.

! Thereafter, the door can only be closed via the dead man's control. Eliminate the reason for the excessive force being applied, so that the door can be opened and closed again.

Motor 9.24/5.24: input value = U x weight / 20 kg

Motor 9.20: input value = U x weight / 16 kg
Motor 9.15: input value = U x weight / 15 kg

The results are only approximate values; a force measuring run is required to determine the value more precisely.

! When using 6.65DU, the function will be different. Please refer to section "DU Functions" for more details.

Force measuring run to determine the cut-off threshold. After value 99 has been entered in menu 48, the control will carry out a force measuring run:

1. Attach a test weight (recommended approx. 20 kg) at the door and open and close the door completely.
2. Following that, menu 48 displays the value which will be imported as cut-off value. This value can be modified (double value equals double force).
3. Remove the test weight again and open and close the door.

ON period (menu 49)

The ON period set will prevent the drive motor from getting overheated and thus getting damaged.

! When using motor 5.24 with plastic transmission, set the ON period at 1 (3~) or 2 (WS, 1~).

External command units / impulse generators (menu 51)

0 input J1.3 was used to generate a closing impulse, J1.4 to generate an opening impulse.



The gate must remain visible from the place of operating it.

1 inputs are used for OPEN-STOP-CLOSE. J.1.3 for half-opening of the door, J1.4 for full opening of the door.

Programming the radio remote control

Please note that each hand transmitter must be individually programmed. It is possible for up to 30 radio codes to be learned. The following functions can be taught in. KeeLoq, 12 Bit Multibit. The first code determines the type.

Selection of the control type (menu 59)

The various control types can be selected from menu 59. Please refer to the supplementary sheets for the settings.

Start impulse (menu 60)

Enter the menu and press the button on the hand transmitter for the START function. As soon as the code has been learned, the incremental display flashes five times.

Half-open position of the door (menu 61)

Enter the menu and press the button on the hand transmitter for the half-open position. As soon as the code has been learned, the incremental display flashes five times.

Light function (menu 62)

Enter the menu and press the button on the hand transmitter for the light function. As soon as the code has been learned, the incremental display flashes five times.

Deleting radio codes (menu 63)

To delete all the learned codes in the menu, press the oval button and keep it pressed for 5 seconds.

DU Functions (main menu 7)

Reset the control in menu 99 to the factory setting during the commissioning. The function "Opening force limit" in the DU can be selected from menu 48: value = 0, force limit within value = 1 ... 99, force limit has been activated

! In order to protect the drive against overheating, set the operating time to 5 in menu 49.

Programming Overview

GB

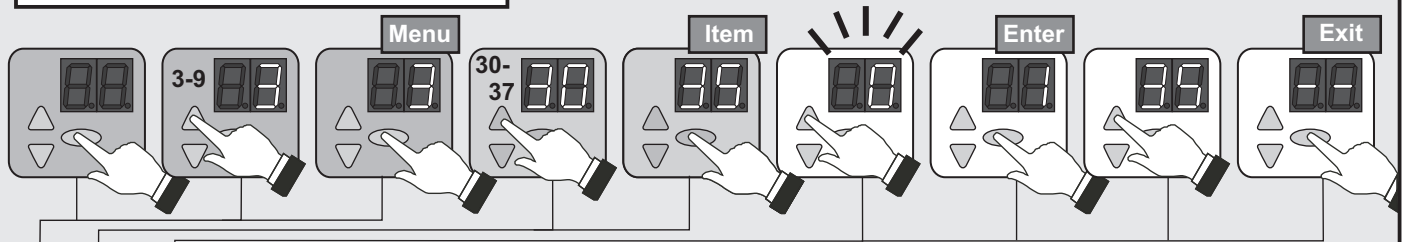

No.	Menu point	Entry	Selection	
3	30		Setting the door's top end-of-travel position	
		○	Change of direction (press for 5 sec.)	
	31		Setting the door's bottom end-of-travel position	
	32		Setting the door's half-open position	
	33	50*		Fine adjustment of top end-of-travel position
		50 - 0		0... 80mm deeper
		50 - 99		0... 80mm higher
	34	50*		Fine adjustment of bottom end-of-travel position
		50 - 0		0... 80mm deeper
		50 - 99		0... 80mm higher
	35			Selecting the closing edge
		0*		Optical closing edge OSE
		1		Electrical safety edge 8K2
		2		Pressure wave edge DW with testing
	36			Selecting the photocell
		0*		without photocell
		1		2-wire photocell LS2
		2		4-wire photocell LS5, Reflection photocell
		3		Frame fitted photocell LS2
		4		Photocell LS5, frame fitted reflection photocell
5			2-wire photocell with stop during Open/Close	
37	25*		Adjustment pre-limit switch safety edge	
	25 - 0		0... 50mm deeper	
	25 - 99		0... 100mm higher	
△	--	○	Exit menu	
4			Selecting the operating modes	
	40	0		Dead man OPEN / Dead man CLOSE
		1		Impulse OPEN / Dead man COSE
		2*		Impulse OPEN / Impulse CLOSE
		3		AR - automatic closing
		4		AR - shortened response time
		5		Open-Close-operation/Red-green-traffic light A800 (option)
	41			Response of safety edge
		0*		Full reversing
	42			Correcting the slowing-down path
		0		off
	43			Level adjustment
		0*		off
		1		activated for 200 cycles
2			activated for 1,000 cycles	

No.	Menu-point	Entry	Selection	
4			Hold-open phase in seconds	
	44	0*		0
		1		10
		2		20
		3		30
		4		40
		5		50
		6		60
		7		90
		8		120
		9		150
		10		180
11			210	
12		240		
45			Status relay X5	
	0*		Door closed signal	
	1		Door open signal	
	2		2 minutes garage light	
	3		5 minutes garage light	
46			Status relay X6	
	0		Door closed signal	
	1*		Door open signal	
	2		Red traffic light without early warning phase	
	3		Red traffic light with 3 seconds early warning phase	
47			Spring breakage detection	
	○		Display spring balance (press 5 sec.)	
	0*		off	
48	1 - 99		Input spring force	
			Opening force limit	
	0*		off	
49	1 - 98		Input cut-off force	
	99		Carry out weight measuring run with test weight	
			Motor starting time	
	0*		Without limitation	
	1		Drive motor 5.24 25 min / 35 %	
	2		Drive motor 5.24 WS 25 min / 30 %	
3		Drive motor 9.15, 9.20, 9.24 25 min / 60 %		
4		Drive motor 9.24 WS 25 min / 20 %		
5		Drive motor 6.65 DU 10 min / 35 %		
6		Drive motor 14.15 25 min / 60 %		
△	--	○	Exit menu	

* Factory defaults

Programming Overview

GB

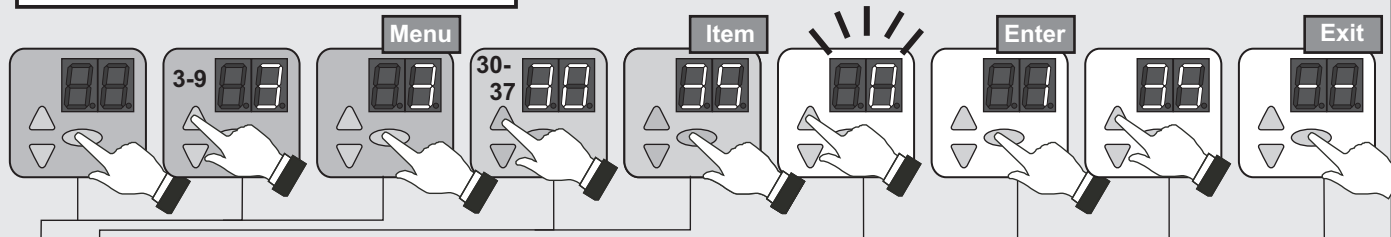

No.	Menu-point	Entry	Selection
5	50		Key switch function (J7)
		0*	Impulse transmitter Open-Stop-Close
		1	Block control panel
		2	Block external control elements
		3	Block control panel and external control elements
		4	Activating the control elements for 10 secs.
		5	Operating mode impulse OPEN / dead man CLOSE
	51	0*	Three-button-control
		1	Open-Stop-Close function (J1.3 1/2-opening J1.4 full-opening)
	52	-	Entering the control address
	53		DC-module
		0*	without DC-module
	--	○	Exit menu
	54		Expansion control
		0*	without expansion control
	59		Selection of the control type (press for 5 sec.)
		18	T100 DES
		19	T100 NES
20		T100 NES with stop command	
21		T100 DES-H height detection	
△	--	○	Exit menu
6	60		Programming the START button on the ransmitter
	61		Programming button for 1/2-opening on the transmitter
	62		Programming the light button on the transmitter
	63	○	Deleting radio codes (press for 5 sec.)
	△	--	○
7	71	30*	Opening speed
		20 - 65	Speed in rpm
	72	20*	Closing speed
		20 - 30	Speed in rpm
	73	0*	Increased closing speed
		20 - 30	Speed in rpm
	74		Door setting change-over point [73] to [72]
	75	20*	Acceleration time open
		05 - 30	x 0.1 sec
	76	20*	Acceleration time close
		05 - 30	x 0.1 sec
	77	20*	Braking time open
05 - 30		x 0.1 sec	
78	20*	Braking time close	
	05 - 30	x 0.1 sec	
△	--	○	Exit menu

No.	Menu-point	Entry	Selection
9	90		Selecting the door's service intervals
		0*	no service interval
		1	1000 cycles
		2	4000 cycles
		3	8000 cycles
		4	12000 cycles
		5	16000 cycles
		6	20000 cycles
		7	25000 cycles
		8	30000 cycles
		9	35000 cycles
		10	40000 cycles
	11	45000 cycles	
12	50000 cycles		
91		Issue of cycles counter - cycles -	
96		Issue of operating hours counter - hours -	
97		Issue of error memory - hours - error code -	
98		Issue of - software version - serial-no. - date -	
99	○	Resetting of factory setting (press for 5 sec.)	
△	--	○	Exit menu

* Factory defaults

Operating instructions / Description of function

The control unit allows a variety of operating modes:

Dead man OPEN / dead man CLOSE

Pressing button and keeping it pressed causes the door to open until the OPEN end-of-travel position is reached. Releasing the button causes the door to stop. The door is closed by dead man's control, i.e. pressing button and keeping it pressed, until the door reaches its CLOSE end-of-travel position. If the button is released during closing, the door stops instantly.

Impulse OPEN / dead man CLOSE

By briefly pressing the button or generating an impulse from an external impulse generator, the door starts to open until reaching the OPEN end-of-travel position or the door can be stopped beforehand by pressing button . If button is pressed again, the door continues to open. The door is closed by dead man's control, i.e. pressing button and keeping it pressed, until the door reaches its CLOSE end-of-travel position. If the button is released during closing, the door stops instantly.

Impulse OPEN / impulse CLOSE

By briefly pressing button or generating an impulse from an external impulse generator the door starts to open until reaching the OPEN end-of-travel position, or the door can be stopped beforehand by pressing button . By briefly pressing button the door starts closing until reaching the CLOSE end-of-travel position.

This operating mode demands that a safety edge (menu 35) be installed. If the safety edge is triggered during closing, the door stops and changes direction. If the safety edge is triggered during opening, this has no effect. In the case of a defect, the door can be closed by pressing button .

AR-mode / automatic closing

By briefly pressing button or generating an impulse from an external impulse generator, the door starts opening until reaching the OPEN end-of-travel position. Or the door was stopped prematurely using button . Once the set hold-open time has elapsed, there follows an early warning phase of 10 seconds, after which time the door automatically closes.

If button is pressed when the door is in the open position or while it is closing, the door is immobilized until a new impulse or is generated.

If menu 36 has been set to 5 or 6, the gate will stop during its travel. Subsequently, the hold-open time will re-start.

AR-mode with shortened response time via photocell

Function as described above, but an interruption of the photocell causes the set hold-open time to be terminated and the early warning phase to begin. After the early warning phase has expired, the door automatically closes.

OPEN-CLOSE operation

However, the receiver remains plugged into the drive in the same operating mode like the one-way control with the red-green traffic light (optional traffic light control A800).

Operating sequence for external impulse generators:

Generating an impulse in the close position:

Drive starts and moves the door into the open position

Generating an impulse during the opening:

Door continues to move without being affected

Generating an impulse in the open position:

Door closes

Generating an impulse during the closing:

Door stops and opens again

Half-opening of the door

Pressing the $\frac{1}{2}$ button initiates the set half-opening of the door (menu 32). This function is not available in the dead man OPEN / dead man CLOSE operating mode.

Lighting and / or early warning light

The control unit has two relay outputs allowing the switching of lighting or the early warning light (menu 45 and 46).

Key switch function (optional)

The control unit has an input for a key switch. This allows you to activate the following functions (menu 50):

- | | |
|---|--|
| 0 | Impulse transmitter Open-Stop-Close |
| 1 | Control panel on the control unit is blocked. |
| 2 | All external control elements are blocked. |
| 3 | Control panel on the control unit and all external control elements are blocked. |
| 4 | For 10 secs. the control panel on the control unit and all the external control elements are active. |
| 5 | Switching of operating mode to impulse OPEN / dead man CLOSE. |
| 6 | Half-opening of the door only. |

External command units / impulse generators

The door can be opened and closed via external command units/impulse generators.

Radio hand transmitter (optional)

Button: Start

First impulse:

The operator starts up and causes the door to travel to the set OPEN or CLOSE travel limits.

Impulse generated during travel:

Door stops.

A new impulse is generated:

Door continues to travel but in the opposite direction.

AR-function:

An impulse is generated:

Door opens.

$\frac{1}{2}$ button for half-opening:

Function as with the START button, but the door travels to the set half-open position only.

Button: Light

The light function involves a continuous light that can be switched on/off independent of the door action.

Maintenance / Checks



For your own safety, we recommend that prior to initial operation and whenever required - however at least once a year, you have the door system tested by a specialist company.

Service display

If the control unit establishes the need for testing / inspection, "service" shows up in the display. Contact a specialist company.

Error	State	Diagnosis / Remedy
E05	Door neither opens nor closes	The slack cable switch has tripped (see Fig. 8c).
E06	Door reverses / does not close	Closing edge has been triggered. Check menu setting [35].
E07	Door reverses / does not close	Photocell has been triggered. Check menu setting [36].
E08	Door neither opens nor closes	External safety device (emergency-STOP, slack cable, wicket door, motor's thermal switch) has been activated. Check (J4).
E09	Door neither opens nor closes	No end-of-travel positions learned. Programme the end-of-travel positions [30] [31].
E10	Menu 36 set at 3 or 4	Allow door to open and close fully in order for the position of the photocell to be detected.
F2	No response	Error occurred during self-testing, exchange control unit.
F3	No response	Error occurred during self-testing, exchange control unit.
F4	No response	Error occurred during self-testing, exchange control unit.
F5	No response	Error occurred during self-testing, exchange control unit.
F06	No response	Safety edges defective, Check voltage (J3.3 - J3.1 >12V).
F07	Door neither opens nor closes	The 24V power supply has broken down. Check the connections.
F08	Extension module function defective	Fault in the add-on controls. Check the add-on controls.
F10	Door stops shortly after START command given	Door neither opens nor closes. Malfunction in the control unit electronics. Replace control unit.
F19	Door responds only to dead man's control for closing	Closing edge self-testing has failed. Check safety edge.
F20	Door responds only to dead man's control for closing	Photocell self-testing has failed. Check photocell.
F21	Operation briefly interrupted	Door operator's excess travel stop activated, allow operator to cool down for approx. 20 min.
F23	No response to START command	Door's end-of-travel positions defective. Check end-of-travel positions and if necessary re-adjust.
F24	No response to START command	No connection to DES. Check motor connecting lead and DES.
F25	No response	Internal testing of membrane keypad defective. Replace membrane keypad.
F26	No response	Internal testing of external buttons / switches has failed.
F28	No response to START command	Fault in the voltage supply. Check mains connection.
F29	End-of-travel positions shifted Motor not running Motor rotates in the wrong direction	Plausibility error of DES Check mechanics of both motor and door. Check both motor and motor connecting lead. Mains phases have been exchanged; correct or reset.
F30	Door responds only to dead man's control for closing	Returns from impulse to dead man's control. Check safety edges and photocell.
F31	Door neither opens nor closes	Button actuated. Continuous impulse operative. Check external command generators (J1).
F32	Door neither opens nor closes	Spring breakage detection has been activated. Check springs and if necessary replace and programme the end-of-travel positions again.
F33	Door stopped while opening	Opening force limit activated. Thereafter, the door can only be closed via the dead man's control. Eliminate sluggishness or blocking of door. Check springs. Eliminate the reason for the excessive force being applied, so that the door can be opened and closed again.
F34	Door neither opens nor closes	The ON period has been exceeded. Wait and let the motor cool down.
F35	Door neither opens nor closes	The speed monitoring has tripped. Exchange DU drive.
F40	Expansion control	The 24-V power supply has broken down. Check the connections at the expansion control.
F41	Expansion control	Fault during the self-test. Replace the expansion control.

Terms of Guarantee

Dear customer,

During production the industrial door operator you have purchased has undergone various checks by the manufacturer to ensure that it is of impeccable quality. Should this operator or parts of it prove to be of no use or limited use as a result of proven material or manufacturing defects, we shall rectify this, at our discretion, through free-of-charge repair or replacement. We shall not accept any liability for damage as a result of unsatisfactory fitting and installation, improper putting into service, incorrect operation and maintenance, excessive use and overloading as well as any

alterations or modifications carried out to the operator and accessory parts by the customer. The same shall also apply for damage incurred during transit or as a result of force majeure, external influences or natural wear as well as special atmospherical stresses. We cannot accept any liability following alterations or modifications of functional parts carried out by the customer. We must be notified of any defects immediately in writing; on request the parts in question are to be made available to us.

We shall not bear the costs for dismantling and installation, freight and carriage. If a complaint is proven to be unjustified, the customer must bear our costs.

This guarantee is only valid in conjunction with the signed invoice and commences on the day of delivery. The manufacturer guarantees that the product is free of defects. The warranty is granted for a period of 24 months, in as far as the verification overleaf has been properly filled out. Otherwise the warranty shall expire 27 months after the date of manufacture.



Inspection and test log book for the door system

Owner / operator of the system: _____

Location of door system: _____

Operator data:
 Operator type: _____ Date of manufacture: _____
 Manufacturer: _____ Operating mode: _____

Door data:
 Type: _____ Year of construction: _____
 Serial no.: _____ Leaf weight: _____
 Door dimensions: _____

Installation and initial operation
 Company, installer: _____ Name, installer: _____
 Initial operation on: _____ Signature: _____

Other details
 Subsequent alterations _____

General information
 When being put into service power-operated doors must be inspected and maintained by correspondingly qualified persons (persons with suitable training and qualifications based on knowledge and experience) at intervals as specified in the manufacturer's maintenance instructions and, if necessary, also in accordance with any special national regulations (e.g. BGR 232 "Guidelines for Power-operated Windows, Doors and Gates").

Testing of door system
 All inspections and maintenance carried out must be documented in the inspection log book provided. It must be kept safe by the owner-operator, together with the documentation on the door system, throughout the operator's entire service life and must be filled out in full and handed over to the owner-operator by the installer at the latest at the time of putting into service. (We also recommend this for manually operated doors.)
 The manufacturer's guarantee becomes null and void in the event that inspection / maintenance has not been properly carried out.
 Alterations to the door system (in as far as permitted) must also be documented.
Caution: An inspection is not the same as maintenance!

Retain these installation, operating and maintenance instructions for the full duration of the operator's service life!



Check list of door system

(Document the equipment present at the time of initial operation by ticking off)

Equipment	present applicable	Features to be tested	Remark
1.0 Door			
1.1 Manual operation of the door	<input type="checkbox"/>	Smooth running	<input type="checkbox"/>
1.2 Fastenings / connections	<input type="checkbox"/>	State / Seat	<input type="checkbox"/>
1.3 Pivots / joints	<input type="checkbox"/>	State / Lubrication	<input type="checkbox"/>
1.4 Track rollers / track roller holders	<input type="checkbox"/>	State / Lubrication	<input type="checkbox"/>
1.5 Seals / sliding contact strips	<input type="checkbox"/>	State / Seat	<input type="checkbox"/>
1.6 Door frame / Door guide	<input type="checkbox"/>	Alignment / Fastening	<input type="checkbox"/>
1.7 Door leaf	<input type="checkbox"/>	Alignment / State	<input type="checkbox"/>
2.0 Weight counterbalance / safe opening			
2.1 Springs	<input type="checkbox"/>	State / Seat / Setting	<input type="checkbox"/>
2.1.1 Clamping heads / bearing blocks	<input type="checkbox"/>	State	<input type="checkbox"/>
2.1.2 Spring safety device	<input type="checkbox"/>	State / Data plate	<input type="checkbox"/>
2.1.3 Safety elements	<input type="checkbox"/>	State / Seat	<input type="checkbox"/>
2.2 Wire cables	<input type="checkbox"/>	State / Seat	<input type="checkbox"/>
2.2.1 Cable fastening	<input type="checkbox"/>	State / Seat	<input type="checkbox"/>
2.2.2 Cable drums	<input type="checkbox"/>	2 safety windings	<input type="checkbox"/>
2.2.3 Slack cable switch	<input type="checkbox"/>	State / Seat / Function	<input type="checkbox"/>
2.3 Anti-fall safeguard	<input type="checkbox"/>	State	<input type="checkbox"/>
2.4 Concentricity of T-shaft	<input type="checkbox"/>	State	<input type="checkbox"/>
3.0 Operator / controls			
3.1 Operator / support bracket	<input type="checkbox"/>	State / Fastening	<input type="checkbox"/>
3.2 Electrical cables / connections	<input type="checkbox"/>	State	<input type="checkbox"/>
3.3 Emergency release	<input type="checkbox"/>	State / Function	<input type="checkbox"/>
3.3.1 Quick chain	<input type="checkbox"/>	State / Function	<input type="checkbox"/>
3.3.2 Crank handle	<input type="checkbox"/>	State / Function	<input type="checkbox"/>
3.3.3 Quick release	<input type="checkbox"/>	State / Function	<input type="checkbox"/>
3.4 Control devices, push-button / hand transmitter	<input type="checkbox"/>	State / Function	<input type="checkbox"/>
3.5 Travel cut-out	<input type="checkbox"/>	State / Function	<input type="checkbox"/>
4.0 Safeguarding of crush and shearing zones			
4.1 Force limit	<input type="checkbox"/>	Stops and reverses	<input type="checkbox"/>
4.2 Safeguards to prevent persons from being lifted up by the door	<input type="checkbox"/>	Door leaf	<input type="checkbox"/>
4.3 Site conditions	<input type="checkbox"/>	Safety distances	<input type="checkbox"/>
5.0 Other devices			
5.1 Latching / lock	<input type="checkbox"/>	State / Function	<input type="checkbox"/>
5.2 Wicket door	<input type="checkbox"/>	Function / State	<input type="checkbox"/>
5.2.1 Wicket door contact	<input type="checkbox"/>	Function / State	<input type="checkbox"/>
5.2.2 Door closer	<input type="checkbox"/>	Function / State	<input type="checkbox"/>
5.3 Traffic light control	<input type="checkbox"/>	Function / State	<input type="checkbox"/>
5.4 Photocells	<input type="checkbox"/>	Function / State	<input type="checkbox"/>
5.5 Safety edge	<input type="checkbox"/>	Function / State	<input type="checkbox"/>
6.0 Documentation of the operator / owner			
6.1 Data plate / CE marking	<input type="checkbox"/>	complete / readable	<input type="checkbox"/>
6.2 Door system's declaration of conformity	<input type="checkbox"/>	complete / readable	<input type="checkbox"/>
6.3 Installation, Operating and Maintenance instructions	<input type="checkbox"/>	complete / readable	<input type="checkbox"/>

Retain these installation, operating and maintenance instructions for the full duration of the operator's service life!

